

**Location: Town Office, Council Chambers
21 Water Street, 2nd Floor**

**Viewing on: Pioneer Cable – Channel 400
Spectrum Cable – Channel 1301 or Channel 7**

Public Participation thru Zoom:

**Meeting ID: 856 7271 4460
NO PASSCODE NEEDED
CALL-IN: 1-929-205-6099**

AGENDA

Regular Council Meeting

**February 9, 2026
6:00 PM**

Pledge of Allegiance

Public Comments

I. Minutes: Special & Regular Council Meeting of January 26, 2026 and Fiscal Year 2026 Public Hearing of January 26, 2026.

II. Old Business

III. New Business

A. (020126-1) Council confirms the Interim Town Manager's appointment of Emily Mills as Tax Collector.

B. (020126-2) Council confirms the Tax Collector's appointment of Khylee Wampler as Deputy Tax Collector.

C. (020126-3) Council confirms the Tax Collector's appointment of Kimberly Denbow as Deputy Tax Collector.

D. (020126-4) Council confirms the Interim Town Manager's appointment of Emily Mills as General Assistance Administrator.

**E. (020126-5) Council reappoints Galen Hogan, Matthew Nightingale and Terry Beals to the Airport Committee Advisory Board for 3-year terms.
[Thank you for volunteering.](#)**

F. (020126-6) The Town of Houlton ordains that taxes are due and payable when rendered and no later than October 15, 2026, and delinquent taxes shall bear interest at the rate of 7% per annum from and after October 15, 2026 until paid in full, such interest to be added to and become part of the taxes. (Note this is in accordance with MRSA 36, Sec. 505.4)

(Introduction)

This is an annual requirement.

G. (020126-7) The Town of Houlton ordains that taxes in excess of the final assessment shall be repaid from the date of overpayment at 3% interest in accordance with MRSA 36, Sec. 506A.

(Introduction)

This is an annual requirement.

H. (020126-8) Council accepts the bid of \$398,744 from New England Fire Equipment & Apparatus Corporation for a Southeast Extreme Duty Mini Pumper for the Houlton Fire Department and authorizes the Interim Town Manager to go out to bid for financing.

6 bids were received, see memos.

I. (020126-9) Council approves the adoption of the Town of Houlton Freedom of Access Act Policy.

This is one of the requirements of the settlement agreement regarding the town wide camera system.

IV. Discussion and Reports

A. Town Managers Report

B. Councilors' Remarks

V. Adjournment

**Special Council Meeting
January 26, 2026**

Chair Lake called the meeting to order at 5:30 PM with all Councilors present, except Councilor Maguire who was excused.

Executive Session

(S010326-1) It was moved by Councilor Tortello, seconded by Councilor Torres that Council enter Executive Session with the Interim Town Manager for the purpose of discussing personnel matters, pursuant to MRSA Title 1, Section 405(6)A.

Vote was taken as follows: Councilor Grant, yes; Councilor Schools, yes; Councilor Craine, yes; Councilor Torres, yes; Councilor Tortello, yes.

Council entered Executive Session at 5:31 PM and returned to Open Session at 6:06 PM.

V. Adjournment: On motion by Councilor Tortello, seconded by Councilor Torres the meeting adjourned at 6:08 PM with all in favor.

**Regular Council Meeting
January 26, 2026**

Chair Lake called the meeting to order at 6:08 PM with all Councilors present, Councilor Maguire was present via Zoom.

Public Comments - None

I. **Minutes:** It was moved by Councilor Tortello, seconded by Councilor Torres that the Special & Regular Council Meeting of January 12, 2026 and Special Council Meeting of January 14, 2026 minutes be approved as presented.

All were in favor.

II. **Old Business**

A. (S010126-1) Chair Lake declared the Public Hearing open on the following: Council ordains the transfer of up to \$75,000 from the Undesignated Fund Balance to cover the budget shortfall in the Administration Department. The Assistant Town Manager certifies such funds are available.

Chair Lake noted that it's due to overages in payroll and legal.

It was moved by Councilor Tortello, seconded by Councilor Torres to approve the order.

Vote was taken as follows: Councilor Grant, yes; Councilor Schools, yes; Councilor Craine, yes; Councilor Maguire, yes; Councilor Torres, yes; Councilor Tortello, yes.

The order passed.

B. (S010126-2) Chair Lake declared the Public Hearing open on the following: Council ordains the transfer of up to \$72,000 from the Undesignated Fund Balance to cover the budget shortfall in the Ambulance Department. The Assistant Town Manager certifies such funds are available.

Chair Lake noted that it was due to overage in regular payroll, offset by extra revenues.

It was moved by Councilor Tortello, seconded by Councilor Torres to approve the order.

Vote was taken as follows: Councilor Tortello, yes; Councilor Torres, yes; Councilor Maguire, yes; Councilor Craine, yes; Councilor Schools, yes; Councilor Grant, yes.

The order passed.

C. (S010126-3) Chair Lake declared the Public Hearing open on the following: Council ordains the transfer of up to \$44,000 from the Undesignated Fund Balance to cover the budget shortfall in the Civic Center Department. The Assistant Town Manager certifies such funds are available.

Chair Lake noted that it was due to overages in part-time payroll, food/beverage costs, utility costs and equipment maintenance repairs.

It was moved by Councilor Tortello, seconded by Councilor Torres to approve the order.

Vote was taken as follows: Councilor Grant, yes; Councilor Schools, yes; Councilor Craine, yes; Councilor Maguire, yes; Councilor Torres, yes; Councilor Tortello, yes.

The order passed.

III. New Business

A. (010226-1) Chair Lake declared the Public Hearing open on the following: Council approves the application to the Division of Liquor Licensing and Enforcement by Temple Theatre, LLC located at 20 Market Square, for renewal of liquor license.

It was moved by Councilor Tortello, seconded by Councilor Torres to approve the order.

Vote was taken as follows: Councilor Tortello, yes; Councilor Torres, yes; Councilor Maguire, yes; Councilor Craine, yes; Councilor Schools, yes; Councilor Grant, yes.

The order passed.

B. (010226-2) Chair Lake declared the Public Hearing open on the following: Council approves the application for a Victualer License for Kassi McGary d/b/a Epic Vibes located at 66 North Street.

Chair Lake noted that this business is under new ownership.

It was moved by Councilor Tortello, seconded by Councilor Torres to approve the order.

Councilor Tortello wished Ms. McGary success in taking over this business. She noted that Ms. McGary advertised on Facebook over the weekend that they were having a grand reopening on the 24th that said negative temperatures can't kill positive vibes.

Vote was taken as follows: Councilor Grant, yes; Councilor Schools, yes; Councilor Craine, yes; Councilor Maguire, yes; Councilor Torres, yes; Councilor Tortello, yes.

The order passed.

C. (010226-3) Chair Lake declared the Public Hearing open on the following: Council accepts the State of Maine Community Development Block Grant (CDBG) Program funds for a Housing Assistance Grant in the amount of \$30,000 on behalf of Serendipitous Dragonfly, pending completion of the Project Development Phase, and accepts any public comments to be submitted as part of this Phase. (Note: The purpose of the grant is for gap financing for various equipment purchases, working capital and LMI job at Serendipitous Dragonfly)

Nancy Ketch, Community Development Director noted that an amendment would need to be done once this order is on the floor. She noted that it needs to state that it is an Economic Development Program Grant, not Housing Assistance Grant. She noted that Katie Sloat was hoping to be here tonight but was unable to make it.

Ketch noted that this is the CDBG program that a public hearing was done for in the past to apply for financing to help put a children's play area inside of Serendipitous Dragonfly. She noted that the grant is pending the project development phase which requires a public hearing for Council to accept the grant.

It was moved by Councilor Craine, seconded by Councilor Torres to approve the order.

It was moved by Councilor Craine, seconded by Councilor Tortello to amend the order to reflect that this is for an Economic Development Program Grant.

Vote to amend the order was taken as follows: Councilor Grant, yes; Councilor Schools, yes; Councilor Craine, yes; Councilor Maguire, yes; Councilor Torres, yes; Councilor Tortello, yes.

Vote to approve the amended order was taken as follows: Councilor Tortello, yes; Councilor Torres, yes; Councilor Maguire, yes; Councilor Craine, yes; Councilor Schools, yes; Councilor Grant, yes.

The amended order passed.

IV. Discussion and Reports

A. Town Managers Report

Interim Town Manager Ketch reminded everyone that the Town Office will be closed on Wednesday until noon. She also reminded everyone that dog licenses are due this week. She noted that the 30th annual Moosestompers event is February 6th, 7th, and 8th. She noted that a warming center was offered over the weekend and thanked everyone that was involved with the planning. She noted that there weren't any takers but that it was available.

She noted that Serenna Fitzpatrick, Civic Center Supervisor has received some quotes for the damage at the arena after the air exchange froze. She noted that we are waiting to hear back from the insurance company. She noted that the traffic light at the Walmart intersection has been adjusted to 17 feet which is in compliance.

B. Councilors' Remarks

Councilor Schools reminded everyone that the roads are slippery and that the Public Works Department is doing it's best to keep the roads safe. He noted that he lives across the street from the garage and knows that they are out 24/7 when there is a storm. He reminded everyone to slow down.

Councilor Tortello thanked Khylee Wampler for performing above and beyond the call of duty for many months with a smile on her face.

Chair Lake seconded Councilor Tortello's remarks and thanked Khylee. He asked if the equipment at the Civic Center was working correctly. Serenna Fitzpatrick, Civic Center Supervisor explained that the air exchange system is still down until the part arrives.

V. Adjournment: On motion by Councilor Tortello, seconded by Councilor Torres the meeting adjourned at 6:25 PM with all in favor.

**AGENDA
TOWN OF HOULTON
PUBLIC HEARING ON BUDGET FOR FISCAL YEAR 2026**

MONDAY, JANUARY 26, 2026 Immediately following Regular Council Meeting at 6:00 PM

1. Call to Order.

Chair Lake called the meeting to order at 6:25 PM with all councilors present.

2. Council vote on each department budget, as listed.

Administration - \$694,773

Chair Lake declared the Public Hearing open on the Administration budget of \$694,773.

There being no public comments, the Chair closed the Public Hearing.

It was moved by Councilor Tortello, seconded by Councilor Torres to approve the appropriation.

Vote was taken as follows: Councilor Tortello, yes; Councilor Torres, yes; Councilor Maguire, yes; Councilor Craine, yes; Councilor Schools, yes; Councilor Grant, yes.

The order passed.

Assessing - \$190,661

Chair Lake declared the Public Hearing open on the Assessing budget of \$190,661.

There being no public comments, the Chair closed the Public Hearing.

It was moved by Councilor Tortello, seconded by Councilor Torres to approve the appropriation.

Vote was taken as follows: Councilor Grant, yes; Councilor Schools, yes; Councilor Craine, yes; Councilor Maguire, yes; Councilor Torres, yes; Councilor Tortello, yes.

The order passed.

Protection - \$565,861

Chair Lake declared the Public Hearing open on the Protection budget of \$565,861.

There being no public comments, the Chair closed the Public Hearing.

It was moved by Councilor Tortello, seconded by Councilor Torres to approve the appropriation.

Vote was taken as follows: Councilor Tortello, yes; Councilor Torres, yes; Councilor Maguire, yes; Councilor Craine, yes; Councilor Schools, yes; Councilor Grant, yes.

The order passed.

Police - \$1,701,915

Chair Lake declared the Public Hearing open on the Police budget of \$1,701,915.

There being no public comments, the Chair closed the Public Hearing.

It was moved by Councilor Tortello, seconded by Councilor Torres to approve the appropriation.

Vote was taken as follows: Councilor Grant, yes; Councilor Schools, yes; Councilor Craine, yes; Councilor Maguire, yes; Councilor Torres, yes; Councilor Tortello, yes.

The order passed.

Fire - \$760,897

Chair Lake declared the Public Hearing open on the Fire budget of \$760,897.

There being no public comments, the Chair closed the Public Hearing.

It was moved by Councilor Tortello, seconded by Councilor Torres to approve the appropriation.

Vote was taken as follows: Councilor Tortello, yes; Councilor Torres, yes; Councilor Maguire, yes; Councilor Craine, yes; Councilor Schools, yes; Councilor Grant, yes.

The order passed.

Ambulance - \$1,019,542

Chair Lake declared the Public Hearing open on the Ambulance budget of \$1,019,542.

There being no public comments, the Chair closed the Public Hearing.

It was moved by Councilor Tortello, seconded by Councilor Torres to approve the appropriation.

Vote was taken as follows: Councilor Grant, yes; Councilor Schools, yes; Councilor Craine, yes; Councilor Maguire, yes; Councilor Torres, yes; Councilor Tortello, yes.

The order passed.

Health & Social Services - \$28,216

Chair Lake declared the Public Hearing open on the Health & Social Services budget of \$28,216.

There being no public comments, the Chair closed the Public Hearing.

It was moved by Councilor Tortello, seconded by Councilor Torres to approve the appropriation.

Vote was taken as follows: Councilor Tortello, yes; Councilor Torres, yes; Councilor Maguire, yes; Councilor Craine, yes; Councilor Schools, yes; Councilor Grant, yes.

The order passed.

Code Enforcement - \$171,604

Chair Lake declared the Public Hearing open on the Code Enforcement budget of \$171,604.

There being no public comments, the Chair closed the Public Hearing.

It was moved by Councilor Tortello, seconded by Councilor Torres to approve the appropriation.

Vote was taken as follows: Councilor Grant, yes; Councilor Schools, yes; Councilor Craine, yes; Councilor Maguire, yes; Councilor Torres, yes; Councilor Tortello, yes.

The order passed.

Community Development - \$70,817

Chair Lake declared the Public Hearing open on the Community Development budget of \$70,817.

There being no public comments, the Chair closed the Public Hearing.

It was moved by Councilor Tortello, seconded by Councilor Torres to approve the appropriation.

Vote was taken as follows: Councilor Tortello, yes; Councilor Torres, yes; Councilor Maguire, yes; Councilor Craine, yes; Councilor Schools, yes; Councilor Grant, yes.

The order passed.

Cemeteries - \$104,227

Chair Lake declared the Public Hearing open on the Cemeteries budget of \$104,227.

There being no public comments, the Chair closed the Public Hearing.

It was moved by Councilor Tortello, seconded by Councilor Torres to approve the appropriation.

Vote was taken as follows: Councilor Grant, yes; Councilor Schools, yes; Councilor Craine, yes; Councilor Maguire, yes; Councilor Torres, yes; Councilor Tortello, yes.

The order passed.

Public Buildings – Town Office - \$39,351

Chair Lake declared the Public Hearing open on the Public Buildings budget of \$39,351.

There being no public comments, the Chair closed the Public Hearing.

It was moved by Councilor Tortello, seconded by Councilor Torres to approve the appropriation.

Vote was taken as follows: Councilor Grant, yes; Councilor Schools, yes; Councilor Craine, yes; Councilor Maguire, yes; Councilor Torres, yes; Councilor Tortello, yes.

The order passed.

White Building - \$7,255

Chair Lake declared the Public Hearing open on the White Building budget of \$7,255.

There being no public comments, the Chair closed the Public Hearing.

It was moved by Councilor Tortello, seconded by Councilor Torres to approve the appropriation.

Vote was taken as follows: Councilor Tortello, yes; Councilor Torres, yes; Councilor Maguire, yes; Councilor Craine, yes; Councilor Schools, yes; Councilor Grant, yes.

The order passed.

Public Works - \$1,329,414

Chair Lake declared the Public Hearing open on the Public Works budget of \$1,329,414.

There being no public comments, the Chair closed the Public Hearing.

It was moved by Councilor Tortello, seconded by Councilor Torres to approve the appropriation.

Vote was taken as follows: Councilor Grant, yes; Councilor Schools, yes; Councilor Craine, yes; Councilor Maguire, yes; Councilor Torres, yes; Councilor Tortello, yes.

The order passed.

Parks & Recreation - \$319,936

Chair Lake declared the Public Hearing open on the Parks & Recreation budget of \$319,936.

There being no public comments, the Chair closed the Public Hearing.

It was moved by Councilor Tortello, seconded by Councilor Torres to approve the appropriation.

Vote was taken as follows: Councilor Tortello, yes; Councilor Torres, yes; Councilor Maguire, yes; Councilor Craine, yes; Councilor Schools, yes; Councilor Grant, yes.

The order passed.

Parks Maintenance - \$181,659

Chair Lake declared the Public Hearing open on the Parks Maintenance budget of \$181,659.

There being no public comments, the Chair closed the Public Hearing.

It was moved by Councilor Tortello, seconded by Councilor Torres to approve the appropriation.

Vote was taken as follows: Councilor Grant, yes; Councilor Schools, yes; Councilor Craine, yes; Councilor Maguire, yes; Councilor Torres, yes; Councilor Tortello, yes.

The order passed.

Arena - \$357,729

Chair Lake declared the Public Hearing open on the Arena budget of \$357,729.

There being no public comments, the Chair closed the Public Hearing.

It was moved by Councilor Tortello, seconded by Councilor Torres to approve the appropriation.

Vote was taken as follows: Councilor Tortello, yes; Councilor Torres, yes; Councilor Maguire, yes; Councilor Craine, yes; Councilor Schools, yes; Councilor Grant, yes.

The order passed.

Airport - \$197,306

Chair Lake declared the Public Hearing open on the Airport budget of \$197,306.

There being no public comments, the Chair closed the Public Hearing.

It was moved by Councilor Tortello, seconded by Councilor Torres to approve the appropriation.

Vote was taken as follows: Councilor Grant, yes; Councilor Schools, yes; Councilor Craine, yes; Councilor Maguire, yes; Councilor Torres, yes; Councilor Tortello, yes.

The order passed.

Planning Board - \$2,850

Chair Lake declared the Public Hearing open on the Planning Board budget of \$2,850.

There being no public comments, the Chair closed the Public Hearing.

It was moved by Councilor Tortello, seconded by Councilor Torres to approve the appropriation.

Vote was taken as follows: Councilor Tortello, yes; Councilor Torres, yes; Councilor Maguire, yes; Councilor Craine, yes; Councilor Schools, yes; Councilor Grant, yes.

The order passed.

Employee Benefits - \$2,255,193

Chair Lake declared the Public Hearing open on the Employee Benefits budget of \$2,255,193.

There being no public comments, the Chair closed the Public Hearing.

It was moved by Councilor Tortello, seconded by Councilor Torres to approve the appropriation.

Vote was taken as follows: Councilor Grant, yes; Councilor Schools, yes; Councilor Craine, yes; Councilor Maguire, yes; Councilor Torres, yes; Councilor Tortello, yes.

The order passed.

Debt Service - \$280,902

Chair Lake declared the Public Hearing open on the Debt Service budget of \$280,902.

There being no public comments, the Chair closed the Public Hearing.

It was moved by Councilor Tortello, seconded by Councilor Torres to approve the appropriation.

Vote was taken as follows: Councilor Grant, yes; Councilor Schools, yes; Councilor Craine, yes; Councilor Maguire, yes; Councilor Torres, yes; Councilor Tortello, yes.

The order passed.

Other Agencies

Life Flight - \$1,515

Chair Lake declared the Public Hearing open on the Life Flight Budget of \$1,515.

There being no public comments, the Chair closed the Public Hearing.

It was moved by Councilor Tortello, seconded by Councilor Torres to approve the appropriation.

Vote was taken as follows: Councilor Tortello, yes; Councilor Torres, yes; Councilor Maguire, yes; Councilor Craine, yes; Councilor Schools, yes; Councilor Grant, yes.

The order passed.

Chamber of Commerce - \$28,000

Chair Lake declared the Public Hearing open on the Chamber of Commerce budget of \$28,000.

There being no public comments, the Chair closed the Public Hearing.

It was moved by Councilor Tortello, seconded by Councilor Schools to approve the appropriation.

Vote was taken as follows: Councilor Grant, yes; Councilor Schools, yes; Councilor Craine, yes; Councilor Maguire, yes; Councilor Torres, abstain; Councilor Tortello, yes.

The order passed.

Library - \$185,895

Chair Lake declared the Public Hearing open on the Library budget of \$185,895.

There being no public comments, the Chair closed the Public Hearing.

It was moved by Councilor Tortello, seconded by Councilor Torres to approve the appropriation.

Vote was taken as follows: Councilor Tortello, yes; Councilor Torres, yes; Councilor Maguire, yes; Councilor Craine, yes; Councilor Schools, yes; Councilor Grant, yes.

The order passed.

NMDC - \$10,587

Chair Lake declared the Public Hearing open on the NMDC budget of \$10,587.

There being no public comments, the Chair closed the Public Hearing.

It was moved by Councilor Tortello, seconded by Councilor Torres to approve the appropriation.

Vote was taken as follows: Councilor Grant, yes; Councilor Schools, yes; Councilor Craine, yes; Councilor Maguire, yes; Councilor Torres, yes; Councilor Tortello, yes.

The order passed.

Aroostook Area on Aging - \$0

Chair Lake declared the Public Hearing open on the Aroostook Area on Aging budget of \$0.

There being no public comments, the Chair closed the Public Hearing.

It was moved by Councilor Tortello, seconded by Councilor Torres to approve the appropriation.

Vote was taken as follows: Councilor Tortello, yes; Councilor Torres, yes; Councilor Maguire, yes; Councilor Craine, yes; Councilor Schools, yes; Councilor Grant, yes.

The order passed.

Maine Families Aroostook - \$0

Chair Lake declared the Public Hearing open on the Maine Families Aroostook budget of \$0.

There being no public comments, the Chair closed the Public Hearing.

It was moved by Councilor Tortello, seconded by Councilor Torres to approve the appropriation.

Vote was taken as follows: Councilor Tortello, yes; Councilor Torres, yes; Councilor Maguire, yes; Councilor Craine, yes; Councilor Schools, yes; Councilor Grant, yes.

The order passed.

ACAP - \$0

Chair Lake declared the Public Hearing open on the ACAP budget of \$0.

There being no public comments, the Chair closed the Public Hearing.

It was moved by Councilor Tortello, seconded by Councilor Torres to approve the appropriation.

Vote was taken as follows: Councilor Grant, yes; Councilor Schools, yes; Councilor Craine, yes; Councilor Maguire, yes; Councilor Torres, yes; Councilor Tortello, yes.

The order passed.

Day One Windham, ME - \$0

Chair Lake declared the Public Hearing open on the Day One Windham, ME budget of \$0.

There being no public comments, the Chair closed the Public Hearing.

It was moved by Councilor Tortello, seconded by Councilor Torres to approve the appropriation.

Vote was taken as follows: Councilor Tortello, yes; Councilor Torres, yes; Councilor Maguire, yes; Councilor Craine, yes; Councilor Schools, yes; Councilor Grant, yes.

The order passed.

Homeless Services of Aroostook - \$0

Chair Lake declared the Public Hearing open on the Homeless Services of Aroostook budget of \$0.

There being no public comments, the Chair closed the Public Hearing.

It was moved by Councilor Tortello, seconded by Councilor Torres to approve the appropriation.

Vote was taken as follows: Councilor Grant, yes; Councilor Schools, yes; Councilor Craine, yes; Councilor Maguire, yes; Councilor Torres, yes; Councilor Tortello, yes.

The order passed.

Snowmobile Club - \$2,400

Chair Lake declared the Public Hearing open on the Snowmobile Club budget of \$2,400.

There being no public comments, the Chair closed the Public Hearing.

It was moved by Councilor Tortello, seconded by Councilor Torres to approve the appropriation.

Vote was taken as follows: Councilor Tortello, yes; Councilor Torres, yes; Councilor Maguire, yes; Councilor Craine, yes; Councilor Schools, yes; Councilor Grant, yes.

The order passed.

Northern Maine Veterans Cemetery - \$200

Chair Lake declared the Public Hearing open on the Northern Maine Veterans Cemetery budget of \$200.

There being no public comments, the Chair closed the Public Hearing.

Councilor Craine noted that this is a wonderful cause but doesn't feel that taxpayer money should be used for this since it is not located in Houlton.

It was moved by Councilor Tortello, seconded by Councilor Torres to approve the appropriation.

Vote was taken as follows: Councilor Grant, yes; Councilor Schools, yes; Councilor Craine, no; Councilor Maguire, yes; Councilor Torres, yes; Councilor Tortello, yes.

The order passed.

Houlton Canopy Crew - \$2,000

Chair Lake declared the Public Hearing open on the Houlton Canopy Crew budget of \$2,000.

There being no public comments, the Chair closed the Public Hearing.

It was moved by Councilor Tortello, seconded by Councilor Craine to approve the appropriation.

Vote was taken as follows: Councilor Grant, yes; Councilor Schools, yes; Councilor Craine, yes; Councilor Maguire, yes; Councilor Torres, abstained; Councilor Tortello, yes.

The order passed.

SADC - \$28,000

Chair Lake declared the Public Hearing open on the SADC budget of \$28,000.

There being no public comments, the Chair closed the Public Hearing.

It was moved by Councilor Tortello, seconded by Councilor Torres to approve the appropriation.

Councilor Tortello noted that she felt this is money well spent.

Vote was taken as follows: Councilor Tortello, yes; Councilor Torres, yes; Councilor Maguire, yes; Councilor Craine, yes; Councilor Schools, yes; Councilor Grant, yes.

The order passed.

Southern Aroostook Soil & Water Cons. District - \$0

Chair Lake declared the Public Hearing open on the Southern Aroostook Soil & Water Cons. District budget of \$0.

There being no public comments, the Chair closed the Public Hearing.

It was moved by Councilor Tortello, seconded by Councilor Torres to approve the appropriation.

Vote was taken as follows: Councilor Grant, yes; Councilor Schools, yes; Councilor Craine, yes; Councilor Maguire, yes; Councilor Torres, yes; Councilor Tortello, yes.

The order passed.

Tax Abatements - \$20,000

Chair Lake declared the Public Hearing open on the Tax Abatements budget of \$20,000.

There being no public comments, the Chair closed the Public Hearing.

It was moved by Councilor Tortello, seconded by Councilor Torres to approve the appropriation.

Vote was taken as follows: Councilor Tortello, yes; Councilor Torres, yes; Councilor Maguire, yes; Councilor Craine, yes; Councilor Schools, yes; Councilor Grant, yes.

The order passed.

Projects - \$119,250

Chair Lake declared the Public Hearing open on the Projects budget of \$119,250.

There being no public comments, the Chair closed the Public Hearing.

It was moved by Councilor Tortello, seconded by Councilor Torres to approve the appropriation.

Vote was taken as follows: Councilor Grant, yes; Councilor Schools, yes; Councilor Craine, yes; Councilor Maguire, yes; Councilor Torres, yes; Councilor Tortello, yes.

The order passed.

Roads - \$200,000

Chair Lake declared the Public Hearing open on the Roads budget of \$200,000.

There being no public comments, the Chair closed the Public Hearing.

It was moved by Councilor Tortello, seconded by Councilor Torres to approve the appropriation.

Vote was taken as follows: Councilor Tortello, yes; Councilor Torres, yes; Councilor Maguire, yes; Councilor Craine, yes; Councilor Schools, yes; Councilor Grant, yes.

The order passed.

Grant Match - \$5,000

Chair Lake declared the Public Hearing open on the Grant Match budget of \$5,000.

There being no public comments, the Chair closed the Public Hearing.

It was moved by Councilor Tortello, seconded by Councilor Torres to approve the appropriation.

Vote was taken as follows: Councilor Grant, yes; Councilor Schools, yes; Councilor Craine, yes; Councilor Maguire, yes; Councilor Torres, yes; Councilor Tortello, yes.

The order passed.

Capital Reserve - \$434,840

Chair Lake declared the Public Hearing open on the Capital Reserve budget of \$434,840.

There being no public comments, the Chair closed the Public Hearing.

It was moved by Councilor Tortello, seconded by Councilor Torres to approve the appropriation.

Vote was taken as follows: Councilor Tortello, yes; Councilor Torres, yes; Councilor Maguire, yes; Councilor Craine, yes; Councilor Schools, yes; Councilor Grant, yes.

The order passed.

Tax Increment Finance - \$899,703

Chair Lake declared the Public Hearing open on the Tax Increment Finance budget of \$899,703.

There being no public comments, the Chair closed the Public Hearing.

It was moved by Councilor Tortello, seconded by Councilor Torres to approve the appropriation.

Vote was taken as follows: Councilor Grant, yes; Councilor Schools, yes; Councilor Craine, yes; Councilor Maguire, yes; Councilor Torres, yes; Councilor Tortello, yes.

The order passed.

Total Municipal Budget - \$12,217,498

Chair Lake declared the Public Hearing open on the Total Municipal Budget of \$12,217,498.

There being no public comments, the Chair closed the Public Hearing.

It was moved by Councilor Tortello, seconded by Councilor Torres to approve the appropriation.

Vote was taken as follows: Councilor Tortello, yes; Councilor Torres, yes; Councilor Maguire, yes; Councilor Craine, yes; Councilor Schools, yes; Councilor Grant, yes.

The order passed.

Mandates - \$4,043,673

County - \$927,825

RSU #29 - \$3,115,848

Chair Lake declared the Public Hearing open on the Mandates budget of \$4,043,673.

There being no public comments, the Chair closed the Public Hearing.

It was moved by Councilor Tortello, seconded by Councilor Torres to approve the appropriation.

Vote was taken as follows: Councilor Tortello, yes; Councilor Torres, yes; Councilor Maguire, yes; Councilor Craine, yes; Councilor Schools, yes; Councilor Grant, yes.

The order passed.

3. Chair Lake declared the Public Hearing open on the total budget expenditures of \$16,261,171 as an amount not to exceed.

There being no public comments, the Chair closed the Public Hearing.

It was moved by Councilor Tortello, seconded by Councilor Torres to approve the order.

Vote was taken as follows: Councilor Tortello, yes; Councilor Torres, yes; Councilor Maguire, yes; Councilor Craine, yes; Councilor Schools, yes; Councilor Grant, yes.

The order passed.

4. Chair Lake declared the Public Hearing open that Council authorize the use of up to \$16,261,171 from revenues to cover the total municipal budget as approved.

There being no public comments, the Chair closed the Public Hearing.

It was moved by Councilor Tortello, seconded by Councilor Torres to approve the order.

Vote was taken as follows: Councilor Grant, yes; Councilor Schools, yes; Councilor Craine, yes; Councilor Maguire, yes; Councilor Torres, yes; Councilor Tortello, yes.

The order passed.

5. Adjournment: On motion by Councilor Tortello, seconded by Councilor Torres, the meeting adjourned at 6:49 PM with all in favor.

III F

Khylee J Wampler

From: Hudson, Laura <Laura.Hudson@maine.gov>
Sent: Monday, January 12, 2026 2:45 PM
To: Hudson, Laura
Subject: Maine Treasurer Lowers Delinquent Tax Rate for 2026

Importance: High

FOR IMMEDIATE RELEASE

Contact: Gregory Olson
Deputy Treasurer

Maine Office of the State Treasurer
Gregory.Olson@Maine.gov

TREASURER PERRY Reduces Interest Rate on Delinquent Property Taxes

Augusta, ME: Augusta, ME –Treasurer Joe Perry announced that the interest rate charged on delinquent property taxes will be reduced from 7.5% to 7.0%. For taxable year 2026, the maximum interest rate that a municipality may charge for delinquent property taxes is 7.0%. Municipalities may vote to determine the rate of interest that shall apply to taxes that become delinquent during a taxable year until those taxes are paid in full.

Statutory background: The maximum rate of interest that can be charged is governed by [Title 36 M.R.S. Section 505\(4\)](#):

“The maximum rate of interest must be established by the Treasurer of State and may not exceed the prime rate as published in the Wall Street Journal on the first business day of the calendar year, rounded up to the next whole percent plus 3 percentage points. The Treasurer of State shall post that rate of interest on the Treasurer of State's publicly accessible website on or before January 20th of each year. The interest must be added to and become part of the taxes.”

About OST: The Office of the State Treasurer provides state agencies with efficient banking and financial services, which include revenue collection, payment issuance, reconciliation, and trust management. The Office also manages state investments and debt payments and issuance, ensuring that bonds authorized by voters are efficiently sold in the marketplace to provide funding for capital projects statewide. Over \$390 million in unclaimed funds for Maine residents are managed by the Office of the Treasurer. FMI, www.maine.gov/treasurer

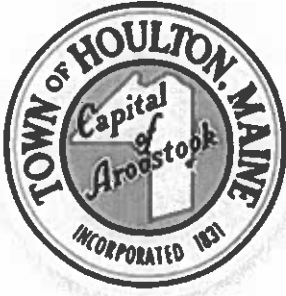

Town of
Houlton
Maine

III H

Subject: Southeast Extreme Duty Mini Pumper – Justification, Capabilities, Community Benefits, and Long-Term Value

Dear Members of the Town Council,

The Houlton Fire Department Committee respectfully recommends approval of the Southeast Extreme Duty Mini Pumper proposal. This apparatus meets all critical specifications outlined in our RFP and represents the strongest long-term investment in safety, reliability, and operational capability for the Town of Houlton.

Background and Process

This apparatus has been included in the Town's capital plan for several years. During the 2024 budget process, the idea of reusing the Fire Chief's vehicle and retrofitting it for this purpose was discussed. The Fire Department Committee met with vendors and researched the feasibility of this option and determined that it was **not recommended** and would provide only a short-term solution. The most significant concern was that the existing chassis would be **overloaded**, creating a safety hazard.

The Fire Department Committee, consisting of five members, met multiple times with the former Town Manager and agreed to develop specifications for a **multi-use apparatus** capable of serving multiple operational roles. Over the summer, the committee held several working sessions and drafted detailed specifications that were put out to competitive bid. A total of **six proposals** were received. The recommendation was to utilize TIF funds that were earmarked for public safety for this need.

This process began at this time last year as part of the budget process and based on current manufacturer timelines, once the contract is awarded, the apparatus is expected to take **up to 12 months** to be delivered.

Justification for Selection

While the lowest-cost proposal was carefully reviewed, it failed to meet several essential requirements:

- **Unproven Body Design:** The plastic/poly body construction is new to the fire service and lacks a track record for durability in northern Maine's extreme climate.
- **Reduced Pump Capacity:** The pump is approximately **40% smaller** than required and lacks critical operational controls.
- **Extended Delivery Time:** The proposed delivery timeline was significantly longer than that of other qualified bidders.

This apparatus will serve the community for **25 years or more** and will replace a **32-year-old vehicle** that is no longer in service. For that reason, durability, proven construction, and full compliance with specifications are vital.

Community Benefits

- **Improved Emergency Response:** Enhanced maneuverability provides faster, safer access to rural roads, tight neighborhoods, and off-road areas.
 - **Enhanced Fire Protection:** A **300 GPM @ 50 PSI** pump and integrated foam system offer superior capability for both structural and wildland firefighting.
 - **Public Safety Assurance:** NFPA-compliant lighting, reflective chevrons, and advanced warning systems increase visibility and reduce roadside hazards.
 - **All-Hazards Preparedness:** The unit supports EMS calls, service responses, wildland fire operations, HazMat incidents, and off-road rescue missions—strengthening the town's overall emergency response capability.
-

Additional Capabilities

- **Extreme Duty Construction:** All-aluminum body and sub-frame with a **20-year structural warranty** and **10-year body warranty** ensure long-term reliability.
 - **Advanced Technology:** Whelen Core lighting system, traffic advisor, perimeter ground lights, backup camera, and a Xantrex inverter-charger system enhance safety and convenience.
 - **Operational Efficiency:** Electric valves, advanced pump controls, and a Hannay electric rewind booster reel streamline operations for both new and experienced personnel.
 - **Included Equipment:** Forestry hose, TFT nozzles, PPV fan, forcible entry tools, and extinguishers reduce future equipment expenditures.
-

Value to the Town

- **Reliability in Harsh Conditions:** Proven aluminum construction withstands extreme cold, snow, and rugged terrain.
 - **Reduced Downtime:** Estimated **9-month manufacturer delivery**, significantly faster than lower-cost alternatives.
 - **Long-Term Return on Investment:** Extended warranties and heavy-duty design reduce lifecycle costs and ensure reliable service for decades.
-

Cost-Benefit Summary

Proposed Price: \$398,744 Bid price was \$389,936 adding On Spot Chains and telescoping lights not included in spec sheet increased cost to \$398,744

Estimated Delivery: 9–12 months

Though higher than the CET proposal **\$310,338**, Bid price was \$299,990 modifications to hose bed and pump to meet specs increased the cost to \$306,440, adding the On Spot Chains and telescoping lights increased the costs to \$310,338. The Southeast Extreme Duty Mini Pumper offers: Superior durability and climate-resilient construction

- Full-size pump capacity with complete operational controls
- Up to **20-year warranties**
- Faster and more reliable delivery timeline
- Fully meets specifications in RFP

These advantages substantially reduce long-term risk, improve operational readiness, and ensure the apparatus aligns with the department's critical mission needs.

The Southeast Extreme Duty Mini Pumper represents the best overall value and the safest long-term choice for restoring full firefighting capability, protecting lives and property, and ensuring responsible stewardship of taxpayer funds.

Thank you for your time and consideration.

Respectfully,

Chief Milton Cone, Deputy Chief James Brown, Asst. Chief Jon Harbison, Asst. Chief Ryan Aucoin, Driver\Fire Fighter Brent Eastbrook
Houlton Fire Department Committee

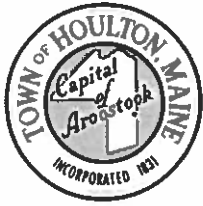

**TOWN OF HOULTON
COMMUNITY DEVELOPMENT DEPARTMENT
21 WATER STREET ♦ HOULTON, MAINE 04730**



Phone: (207) 521-5938

comm.development@houlton-maine.com

Fax: 207-532-1304

MEMO

To: Houlton Town Councilors
From: Nancy Ketch, Interim Town Manager
Date: February 6, 2026
Re: Recommendation For Mini-Pumper Purchase

Following discussions with Chief Cone, Deputy Chief Brown and Town Treasurer as well as consultation with state TIF authorities, I offer the following recommendation for the purchase of the Mini-Pumper for the Houlton Fire Department. We have determined that TIF funds can not be used for the full purchase price of this apparatus.

I recommend approval of the bid outlined in the memo from the Fire Department for \$398,744.

I further recommend that the cost be covered through a combination of a down payment and financing.

Based on the time of production for this apparatus, we anticipate making a down payment of \$115,000 in November of 2026. We propose financing the remaining \$283,744 over five (5) years. Based on research of local borrowing rates, we estimate annual payments of approximately \$66,000 with the first payment being due in 2027 and the final payment due in 2031.

We have been advised that we can most likely cover some percentage of the cost from TIF Public Safety funds. The exact percentage has not yet been determined. It will probably not exceed 15% of the cost. There are a couple of options for use of the TIF funds for covering the cost of the new truck.

1. We could cover a portion of the down payment with TIF Public Safety funds and cover the remainder from the Undesignated Fund Balance. We will have audited figures for the account before the funds are needed.
2. We could cover a portion of the annual payments with TIF funds and then cover the remainder from debt service.
3. If it is determined that minimal TIF funds can be used for this purchase, the annual payments could be covered through debt service. We have recently retired \$280,732 from debt service.



*New England Fire Equipment & Apparatus Corp.
 10 Stillman Road
 North Haven, CT. 06473
 Phone (203) 239-5678 Fax (203) 234-7398 E-mail: nefea@aol.com*

FIRE APPARATUS PROPOSAL

Date: October 31, 2025

Buyer: Town of Houlton -

We hereby propose and agree to manufacture and furnish, after your acceptance of this proposal and the proper execution of a contract or a purchase order, the following apparatus and equipment to be built in accordance with the attached specifications.

Model: One (1) 2026 Southeast Mini Pumper

For the Sum of: \$389,936.00

Three Hundred Eighty-Nine Thousand Nine Hundred Thirty-Six Dollars (In Words)

Terms: Payment due upon delivery acceptance by the Houlton Fire Department.

The amount above in the proposal shall remain firm for a period of 30 days from the date of same. All state, federal and local taxes are not included above. Any applicable taxes are to be paid by Buyer upon registration and licensing of vehicle.

Delivery to be made within 270 days after receipt and approval of contract or purchase order, properly executed, subject to all causes beyond our control such as supply chain interruptions or 3rd party supplier shortages/shutdowns.

Respectfully submitted,

PL Custom

Richard E. Peck II
Date: October 31, 2025

BUYER

 Date: _____

HOULTON FIRE DEPARTMENT

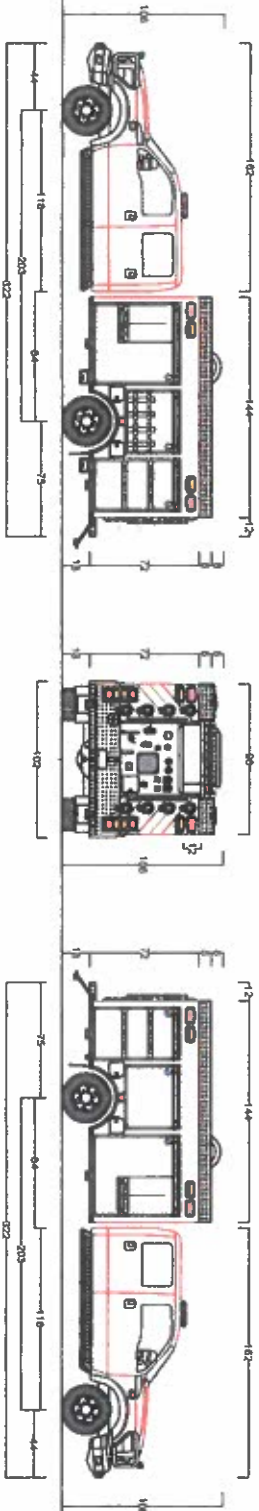

ALL DIMENSIONS SHOWN UNLESS OTHERWISE SPECIFIED ARE IN INCHES. DIMENSIONS ARE GIVEN TO CENTER UNLESS OTHERWISE SPECIFIED. DIMENSIONS TO CENTER UNLESS OTHERWISE SPECIFIED.

THIS DRAWING IS THE PROPERTY OF SOUTHEAST APPARATUS. IT IS TO BE USED ONLY FOR THE SPECIFIC PURPOSES AND CONDITIONS FOR WHICH IT WAS DESIGNED. ANY OTHER USE OR REPRODUCTION OF THIS DRAWING WITHOUT THE WRITTEN PERMISSION OF SOUTHEAST APPARATUS IS STRICTLY PROHIBITED.

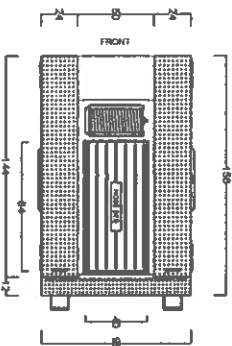

THIS DRAWING IS THE PROPERTY OF SOUTHEAST APPARATUS. IT IS TO BE USED ONLY FOR THE SPECIFIC PURPOSES AND CONDITIONS FOR WHICH IT WAS DESIGNED. ANY OTHER USE OR REPRODUCTION OF THIS DRAWING WITHOUT THE WRITTEN PERMISSION OF SOUTHEAST APPARATUS IS STRICTLY PROHIBITED.

CUSTOM BUILT EMERGENCY VEHICLES

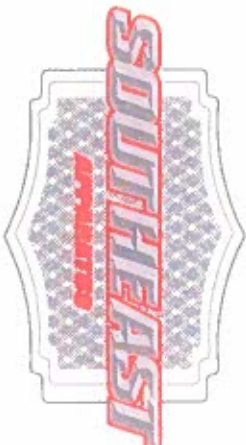

www.southeastapparatus.com | 888.986.6277

**NEW ENGLAND FIRE
EQUIPMENT & APPARATUS**

SOUTHEAST APPARATUS

2028 FORD F-550 CREW CAB COMMERCIAL CHASSIS
 FORD 7.3L GASOLINE ENGINE - 10-SPEED AUTOMATIC
 SOUTHEAST APPARATUS EXTREME DUTY RESCUE BODY
 HALE HPX275-855 GASOLINE PUMP - 300 GPM @ 50 PSI
 250 U.S. GALLON POLY TANK - 10 U.S. GALLON FOAM CELL

Date: 10/31/25 Drawing Version: 1.0

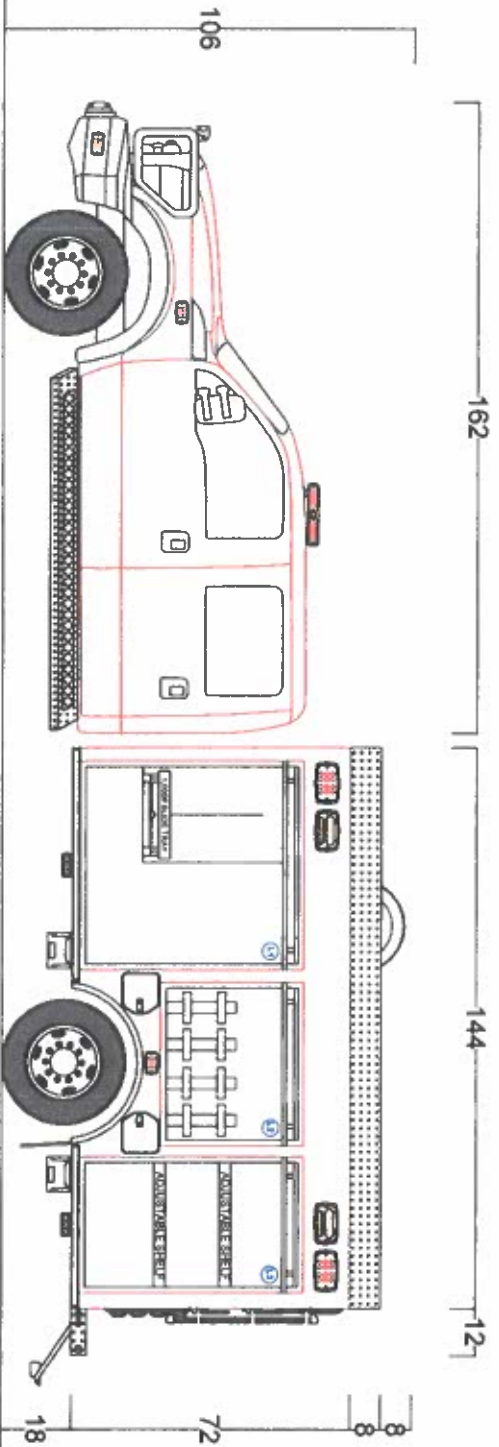

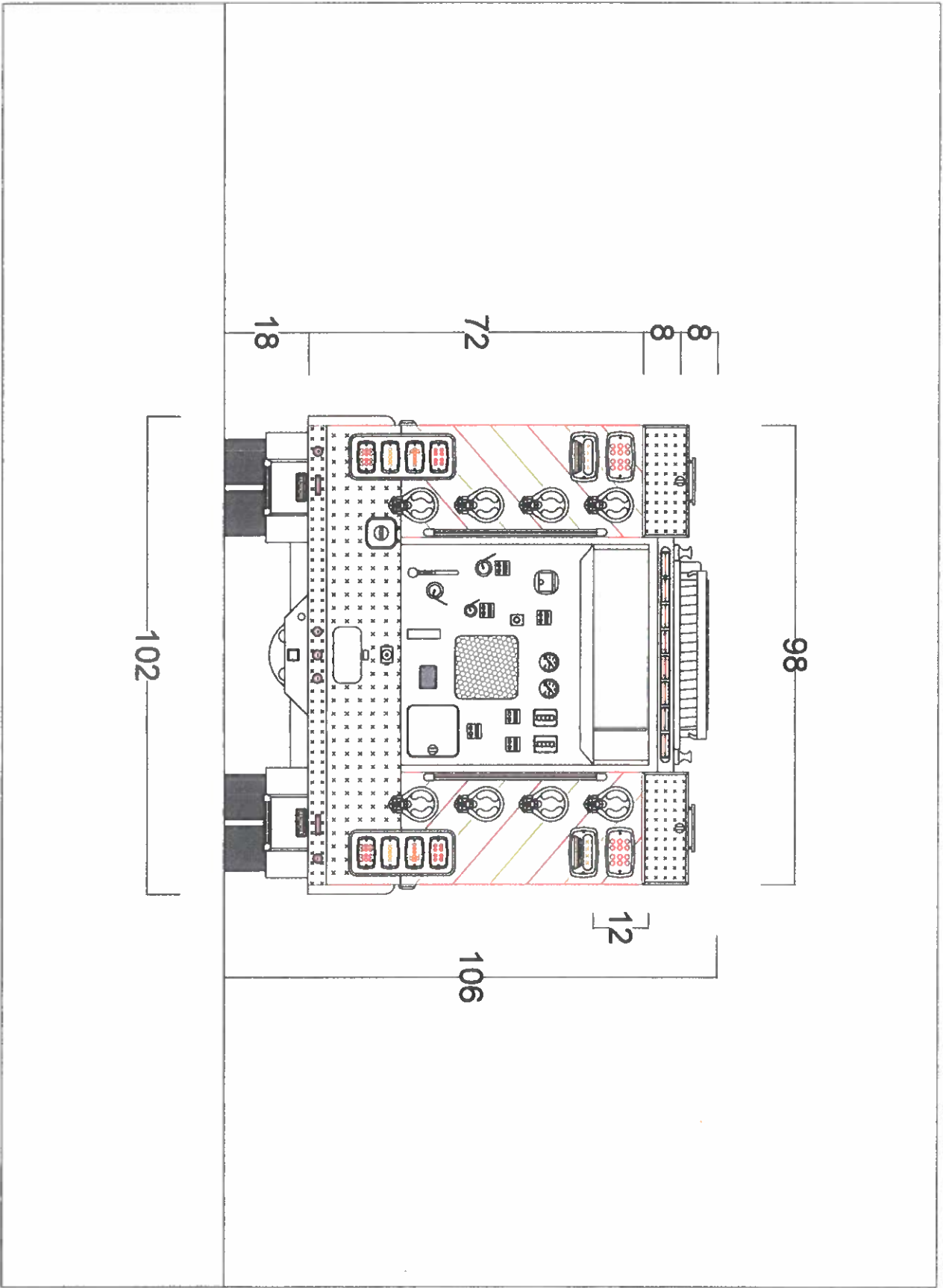

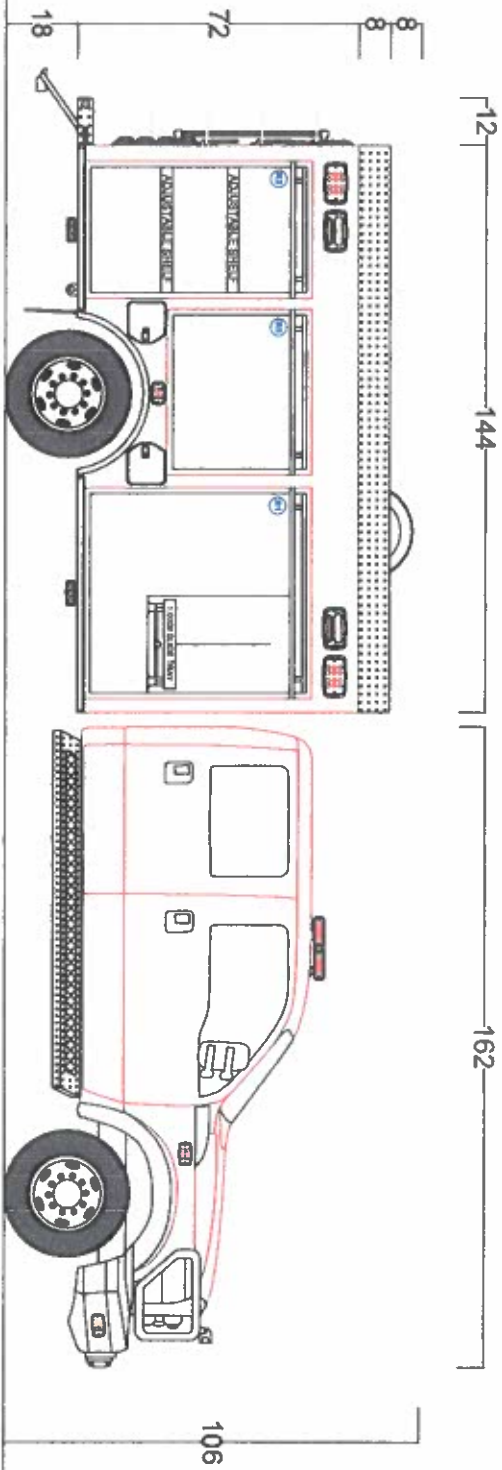

K & T FIRE EQUIPMENT

Metalfab Fire Apparatus Dealer and Warranty Service

FIRE APPARATUS SALES & FIRE APPARATUS REPAIRS

P.O. BOX 360 1143 CRYSTAL ROAD, EXIT 276 , I-95 ROUTE to 159 EAST

ISLAND FALLS , MAINE , 04747,,1 800 675 2848 , 1 207 463 2788 , C.1 207 267 0149

tom.york91@yahoo.com, ktfireequip.com

=====

Metalfab Fire Apparatus" Bid" Mini Pumper

Att; Chief Milton Cone

For: Houlton Fire Dept

Address; 99 Military Street ,Houlton , Maine , 04605

The bidder proposes to construct, manufacturer, engineer, and furnish to the purchaser the following apparatus and equipment to be built to meet the latest edition of NFPA standards as of this date. To include the attached specification, print and chassis.

Metalfab Fire Apparatus BID 3/16" HD Aluminum Extruded Mini Pumper and Equipment

\$ 400,000.00

TO BE BUILT ON Ford F550 provided by York Ford attached spec and price \$ 70,000.00,

Chassis , paid for , registered, and insured prior to delivery to Metalfab, to meet US Custom Import Criteria.

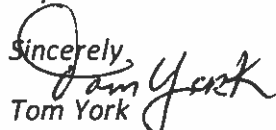
Sincerely,

Tom York

K & T Fire Equipment, Metalfab Fire Apparatus Dealer, Fire Apparatus Service, Crystal Co Poly Tanks, Metalfab Poly Tanks ,Waterous , Hale , Darley ,Pump Warranty



VENGEANT APPARATUS SALES & SERVICE

Houlton, ME - Pricing

Houlton Fire Department
99 Military Street
Houlton, ME 04730
October 27, 2025

Deputy Jim Brown,

Listed below is pricing for your consideration. Delivery shall be approximately 24 months depending upon chassis arrival and agreement of our Proposal.

The price of the proposed vehicle is **\$454,380** with payment due as follows:

- Chassis payment due within 15 days of notification of completed chassis
- Within 30 days of start of Production, a payment of 30% of the outstanding balance is requested or a 9% Finance Charge will apply
- Final balance due upon acceptance of completed vehicle at the factory
- Note that the price **includes a \$5,000 Allowance** which can be used;
 - for any design changes requested by the Fire Department
 - equipment purchases and mounting
 - any unused funds will be returned as directed by the Fire Dept.

The price above is valid for 30 days and is all-inclusive – it **includes a Final Inspection trip for two (2) members of the Houlton Fire Department, shipping to Fleetmasters, dealer prep, lettering and striping, as well as apparatus familiarization sessions** at our facility for your members.

The full details of pricing and terms of purchasing this apparatus will be governed by the Sales Contract, to be provided and mutually agreed separately.

I look forward to discussing this proposal with you and working to provide the **Houlton, ME Fire Department** with a tough, dependable and safe Vengeant Apparatus. If you have any questions or need any further assistance, please feel free to contact me.



Thank you,

Charles Nizus
Mfrs. Representative

Proposed
LAYOUT SKETCH TO IMAGES

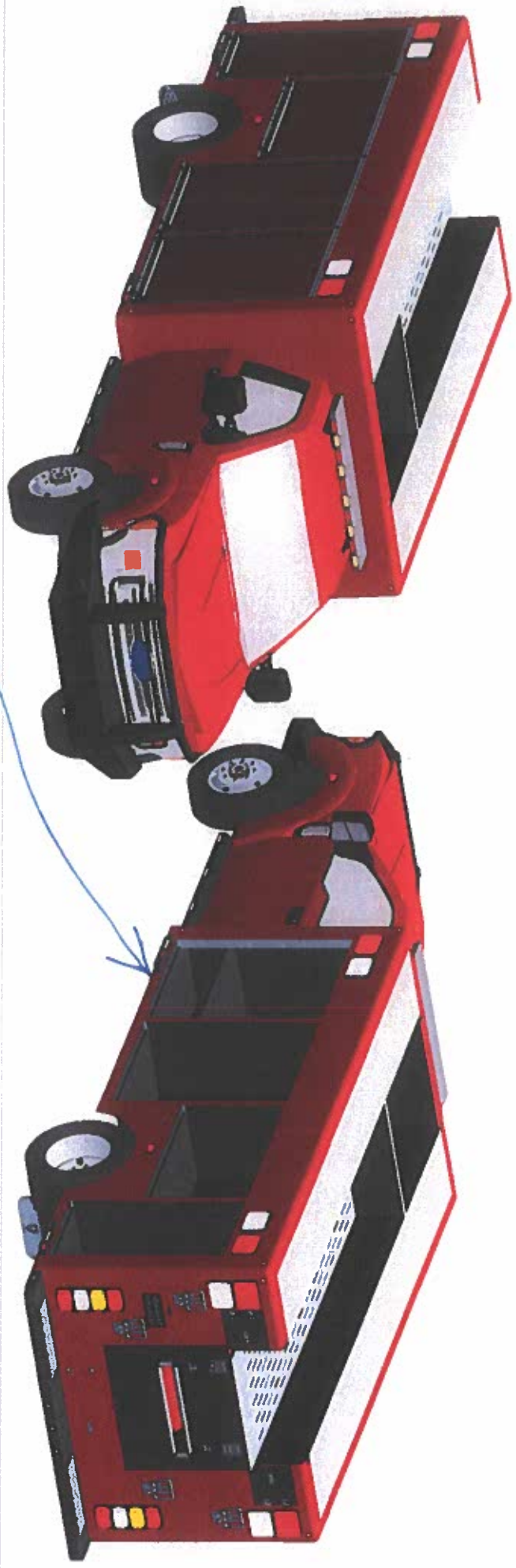

REAR CAB SEATS REPLACE
TRAYS VERSÉ COMPARTMENT



ALLEGIANCE

— FIRE & RESCUE™ —

10/30/2025

Houlton Fire Department, ME
Houlton Fire Department, ME
99 Military Street
Houlton, ME 04730

PROPOSAL BID# O-501977

FOR FURNISHING



The undersigned is prepared to manufacture for you, upon an order being placed by you, for final acceptance by Allegiance Fire & Rescue at its home office in Walpole, Massachusetts, the apparatus and equipment herein named and for the following prices:

One (1) **Skeeter** Utility Body

\$397,285.00

Payment is due upon delivery of product

\$397,285.00

Said apparatus and equipment are to be built and shipped in accordance with the specifications hereto attached, delays due to strikes, war or international conflict, failures to obtain chassis, materials, or other causes beyond our control not preventing, within about 528-572 working days after receipt of this order and the acceptance thereof at our office at Walpole, Massachusetts, and to be delivered to you at the Houlton Fire Department, ME Houlton Fire Department, ME The specifications herein contained shall form a part of the final contract, and are subject to changes desired by the purchaser, provided such alterations are interlined prior to the acceptance by the company of the order to purchase, and provided such alterations do not materially affect the cost of the construction of the apparatus.

The proposal for fire apparatus conforms with all Federal Department of Transportation (DOT) rules and regulations in effect at the time of bid, and with all National Fire Protection Association (NFPA) Guidelines for Automotive Fire Apparatus as published at the time of bid, except as modified by customer specifications. Any increased costs incurred by first party because of future changes in or additions to said DOT or NFPA standards will be passed along to the customers as an addition to the price set forth above.

Unless accepted within 30 days from date, the right is reserved to withdraw this proposition.

ALLEGIANCE FIRE & RESCUE

By: *William K. O'Connor* 30 Oct 2025

William O'Connor - Vice President

SKEETER EMERGENCY VEHICLES

Drawing is for reference only. Exact drawing to be provided at a later date.

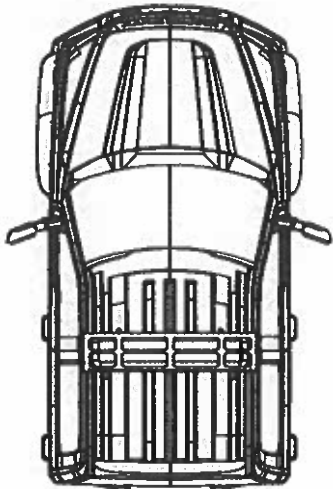
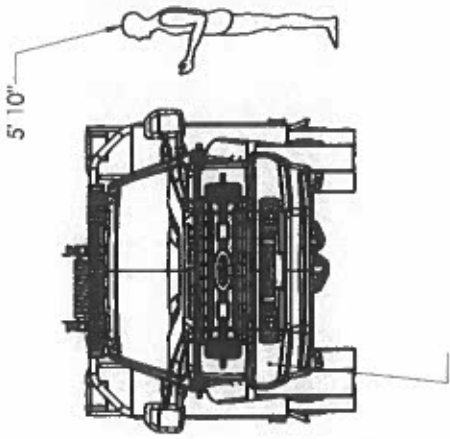

400 Gallon Water Tank w/ 10 Gallons Foam

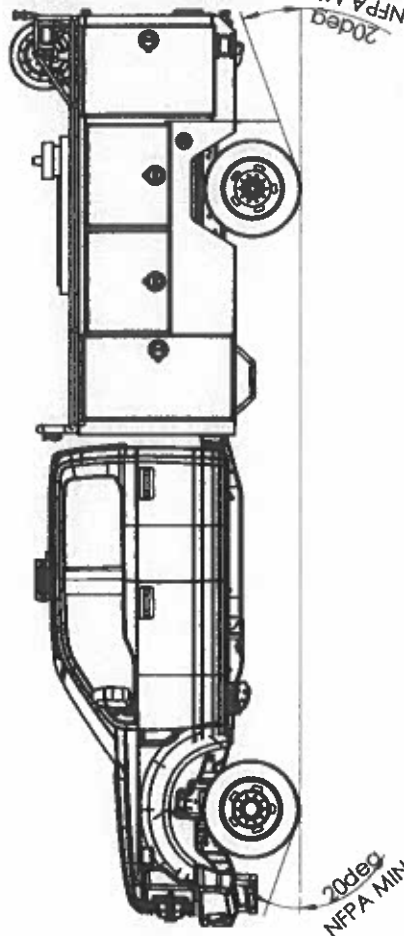
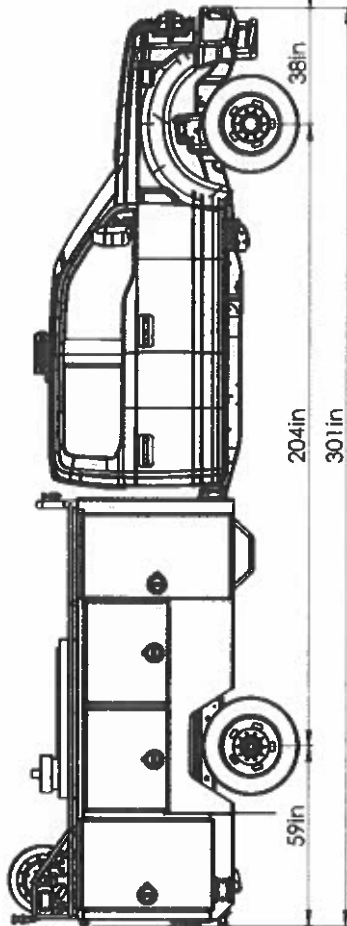
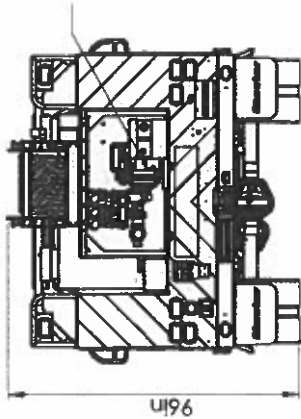
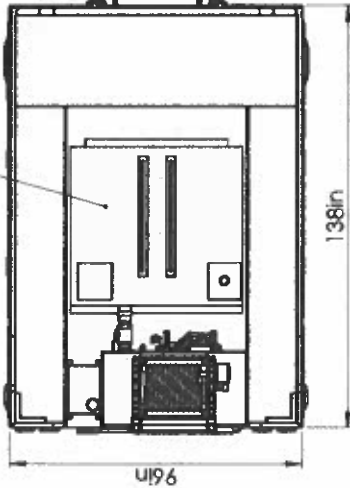

PROPERTY OF SKEETER EMERGENCY VEHICLES

THE DETAILS AND DIMENSIONS SHOWN ARE APPROXIMATE AND ARE SUBJECT TO MAJOR DEVIATIONS AS THEY OCCUR OR BE NECESSARY IN CONSTRUCTION. ALL OTHER DETAILS NOT SHOWN.

PREPARED FOR:

ROGERS FD

DRAWN BY: ALONDRA P.

TITLE:

PRELIMINARY OVERVIEW

SPEC DATE: 4/28/2025

SPEC # 2982

SHEET 1 OF 1

NOT FOR PRODUCTION. SOME FEATURES AND DIMENSIONS SUBJECT TO CHANGE



*New England Fire Equipment & Apparatus Corp.
10 Stillman Road
North Haven, CT. 06473
Phone (203) 239-5678 Fax (203) 234-7398 E-mail: nefea@aol.com*

FIRE APPARATUS PROPOSAL

Date: October 31, 2025

Buyer: Town of Houlton -

We hereby propose and agree to manufacture and furnish, after your acceptance of this proposal and the proper execution of a contract or a purchase order, the following apparatus and equipment to be built in accordance with the attached specifications.

Model: One (1) 2026 Custom Works Mini Pumper

For the Sum of: \$342,616.00

Three Hundred Forty-Two Thousand Six Hundred Sixteen Dollars
(In Words)

Terms: Payment due upon delivery acceptance by the Houlton Fire Department.

The amount above in the proposal shall remain firm for a period of 30 days from the date of same. All state, federal and local taxes are not included above. Any applicable taxes are to be paid by Buyer upon registration and licensing of vehicle.

Delivery to be made within 180 days after receipt of chassis as well as after receipt and approval of contract or purchase order, properly executed, subject to all causes beyond our control such as supply chain interruptions or 3rd party supplier shortages/shutdowns.

Respectfully submitted,

PL Custom



Richard E. Peck II

Date: October 31, 2025

BUYER

Date: _____



MAIN OFFICE

530 John Dietsch Blvd, N. Attleboro, MA 02763
Sales 508.695.7138 Fax 508.699.6842

Tom Shook
Regional Sales Manager
Mid-Coast/Northern Maine
Horton * Wheeled Coach * E-ONE
Cell: (207) 593-6053
Email: tshook@greenwoodev.com

Houlton Fire Department
Attn: Fire Chief Milton Cone
Town of Houlton
21 Water Street
Houlton, ME 04730

Greenwood-North Location
19 Summer St Brunswick, Maine 04011

Chief Cone:

Date: 10/29/2025

I am submitting three bids on behalf of Greenwood Emergency Vehicle for your new Mini Pumper. We have attempted to build a CET that mirrors the specifications provided. Greenwood Emergency Vehicles and I look forward to working on this project with you and starting relationship with the Town of Houlton, Houlton Fire Department and Houlton Ambulance Department. If you have any questions, please contact me or the office.

Greenwood Emergency Vehicle (GEV) has been a dealer of fire and ems apparatus for over 43 years.

We have delivered over 3,000 apparatus in New England and provide service and warranty work in-house. We also employ our own engineer which allows us to do a lot of work in house vs sending back to factories and allows us to do refurbishments in house as well. GEV stocks **over \$1,000,000.00** in parts inventory to expedite repairs of your apparatus. **Knowing how busy everyone is, we offer free pick-up and drop off your apparatus if under our service contract with GEV North.** Being in this business, we understand that the least amount of down time to your emergency vehicle the better. We offer two sites for this work. Our main office is out of Attleboro Falls, Massachusetts (GEV South) and our northern office in Brunswick, Maine (GEV North). **We also provide on the road service also with our service trucks.** This gives the ability to do small repairs and diagnostics at your station verses adding unneeded mileage to your apparatus. **Our service center locations from you are as follows: Brunswick Location: 226 miles and our North Attleboro Location: 398 miles.**

We are a fully self-sufficient dealership, meaning that during the life of your vehicle, there should be no reason that your new CET fire truck would ever have to go back to the OEM. We have our own fabrication department on site. We have our own paint booth on site. We have 4 full time parts department employees. We have 20 full time EVT certified technicians, Master EVT certified technicians and factory trained technicians. We have over 70 employees at our locations with over **600 years** of combined experience in the emergency vehicle industry! We have our own graphics department in-house as well as our own New Truck shop with 6 service bays focusing only on new truck deliveries. When your new truck arrives from CET, all tool layout, equipment mounting, fabrication, and lettering get handled in a clean and well-lit environment. We also have full refurbishing capabilities on site, so we could keep your truck in service for many more years beyond its expected service life. Our service and fabrication facilities offer an additional 10 service bays with 3 sets of vehicle lifts, an overhead hoist, brakes, shears, and all the modern equipment necessary to minimize downtime of your vehicle.

Our Maine Service center is over 7,000 square feet and we offer full pump, mechanical and electrical work on ALL brands of emergency apparatus. We also offer on-site pump testing up to 3,000 GPM with our test pit. We are proud to be a factory authorized service center for both Hale and Waterous pumps. Our service center is staffed with a mix of full time and part time EVT certified and factory trained technicians. We also offer mobile service and pick-up and delivery for all of our Maine and New Hampshire customers. Like our North Attleboro location, you will only see emergency vehicles being work on. Our customers are our priority as are all of your citizens you protect. We strive to provide you with the best service to keep your vehicles on the road protecting those in your community.

CET produces its apparatus at their facility in Pierre Ville, Quebec .

Included in the price are the options listed below:

- **Ford F550 Crew Cab 4x4 7.3L Gas**
- **Polypropylene body**
- **250 gallon water**
- **10 gallon foam tank**
- **Back up Camera System**
- **Foam System**
- **Certified EVT Techs with on the road service available.**

This price includes: *final inspection to the factory for 4 members, prep, lettering, delivery and training on the apparatus.*

We look forward to working with you to get you the new apparatus you need. Feel free to contact me with any questions. Thank you for your time and for considering us as your dealer.

The price of the apparatus as specified is:

Ford F550 Crew Cab Gas CET Mini-pumper \$299,990.00

Pricing is valid for 30 days.

Sincerely,



Tom Shook

Town of Houlton Freedom of Access Act Policy

SCOPE:

This policy applies to requests for public records received by the Town of Houlton pursuant to Maine's Freedom of Access Act ("FOAA"). Public records are defined to be "any written, printed or graphic matter or any mechanical or electronic data compilation from which information can be obtained, directly or after translation into a form susceptible of visual or aural comprehension, that is in the possession or custody of an agency or public official of this State or any of its political subdivisions, or is in the possession or custody of an association, the membership of which is composed exclusively of one or more of any of these entities, and has been received or prepared for use in connection with the transaction of public or governmental business or contains information relating to the transaction of public or governmental business[,]" unless excluded from the definition of a public record pursuant to FOAA, or otherwise designated confidential records by another provision of law. *See* 1 M.R.S. § 402(3).

FOAA ACCESS OFFICER:

All FOAA requests must be immediately directed to the Town's FOAA Access Officer. The Town's FOAA Access Officer is listed on the Town's website: houlton-maine.com. In the event that the FOAA Access Officer is unavailable for more than 3 business days, FOAA requests must be directed to a designated individual to handle the request promptly.

HANDLING FOAA REQUESTS:

The handling of FOAA requests shall be in accordance with the provisions of 1 M.R.S. §§ 400 – 414. The FOAA Access Officer shall acknowledge receipt of a FOAA request within 5 working days of the receipt of the request, and should confirm the scope and content of the request at this time with the requestor. In the event that the FOAA request is unclear or too broad, the FOAA Access Officer will communicate this information to the requestor.

The FOAA Access Officer, in consultation with relevant Town staff as applicable, will compile responsive materials in the possession of the Town that constitute public records in order to respond to the FOAA request.

TIME FRAME

The FOAA Access Officer will provide a non-binding estimate of the amount of time the request may take in order to complete, and will work to complete the request within a reasonable amount of time from receiving the request.

COSTS

The FOAA Access Officer will provide an estimate of fees within a reasonable period of time from receiving the request and will confirm that the requestor would like for the Town to proceed with the request in the event that the cost estimate is greater than \$100. In the event that the cost estimate exceeds \$50, the Town is permitted to require the requestor to pay in advance. In the event that the requestor requests a fee waiver, the Town will make a determination on this request prior to proceeding with the records search. Determinations on granting a fee waiver shall be made by the Town Manager.

FOAA LOG

The FOAA Access Officer will ensure that public record requests received by the Town pursuant to FOAA are logged on the Town’s publicly-accessible FOAA Log. The FOAA Log will contain the following information:

- Date of receipt of the FOAA request
- Date of acknowledgement by the Town of the FOAA request
- Date of response by Town to requestor in connection with FOAA request
- Whether documents were produced fully, in part, or refused
- Specific reason(s) for refusal, including applicable statutory citations
- General description of documents requested

EFFECTIVE DATE: February 9, 2026

Edward Lake, Chair

Jantzen Craine

Susan Tortello

John Schools

Jane Torres

Frederick Grant

Jeffrey Maguire